

### FEATURES:

75W isolated DC-DC converter  
Ultra-wide input and regulated single output

- ◆ Ultra-wide input voltage range:43-160V<sub>DC</sub>
- ◆ High efficiency up to 91%
- ◆ Low no-load power consumption
- ◆ Reinforced insulation,input-output isolation test voltage:3kV<sub>AC</sub>,input-case isolation test voltage:2.1kV<sub>AC</sub>
- ◆ Operating ambient temperature range:-40°C to+105°C
- ◆ Input under-voltage protection,output short-circuit,over-current,over-voltage, over-temperature protection
- ◆ Industry standard 1/4 brick
- ◆ Meets EN50155 railway standard



### Selection Guide

PartNo. <sup>①</sup>	Input Voltage(Vdc)		Output		Full Load Efficiency(%) Min./Typ.	Max.Capacitive Load(μF)
	Nominal (Range)	Max. <sup>②</sup>	Voltage(VDC)	Current(mA) Max./Min.		
CFDQR75-110S03(S)	110 (43-160)	170	3.3	17045/0	84/86	30000
CFDQR75-110S05(S)			5	15000/0	86/88	15000
CFDQR75-110S12(S)			12	6250/0	87/89	4500
CFDQR75-110S15(S)			15	5000/0	87/89	3600
CFDQR75-110S24(S)			24	3125/0	89/91	2250
CFDQR75-110S48(S)			48	1563/0	86/88	360

Note:①Use "S" suffix for heat sink mounting. We recommend to choose modules with a heat sink for enhanced heat dissipation and applications with extreme temperature requirements;

②Exceeding the maximum input voltage may cause permanent damage.

### Input Specifications

Item	Operating Conditions	Min.	Typ.	Max.	Unit	
Input Current(full load/no-load)	Nominal input voltage	3.3V <sub>DC</sub> output	--	595/10	609/20	mA
		24V <sub>DC</sub> output	--	750/10	767/20	
		12V <sub>DC</sub> , 15V <sub>DC</sub> output	--	767/10	784/20	
		05V <sub>DC</sub> , 48V <sub>DC</sub> output	--	775/10	793/20	
Reflected Ripple Current	Nominal input voltage	--	100	--	V <sub>DC</sub>	
Surge Voltage(1sec.max.)		-0.7	--	180		
Start-up Voltage		--	--	43		
Under-voltage Protection		--	40	--		
Input Filter		Pi filter				
Hot Plug		Unavailable				
Cnt*	Module on	Cnt pin open or pulled high(3.5-12V <sub>DC</sub> )				
	Module off	Cnt pin-V <sub>in</sub> or pulled low(0-1.2V <sub>DC</sub> )				
	Input current when off	--	2	10	mA	

Note:\*The Cnt pin voltage is referenced to input-V<sub>in</sub>.

Output Specifications						
Item	Operating Conditions		Min.	Typ.	Max.	Unit
Voltage Accuracy	Nominal input voltage, 0%-100% load		--	±1	±3	%
Linear Regulation	Input voltage variation from low to high at full load	3.3V <sub>DC</sub> , 5V <sub>DC</sub> output	--	--	±0.5	
		Others	--	±0.1	±0.3	
Load Regulation	Nominal input voltage, 10%-100% load	3.3V <sub>DC</sub> , 5V <sub>DC</sub> output	--	±0.5	±1.0	
		Others	--	±0.3	±0.5	
Transient Recovery Time			--	200	500	μs
Transient Response Deviation	25% load step change	3.3V <sub>DC</sub> , 5V <sub>DC</sub> output	--	±6	±9	%
		Others	--	±3	±5	
Temperature Coefficient	Full load		--	--	±0.03	%/°C
Ripple/Noise*	20MHz bandwidth, 10%I <sub>o</sub> -100%I <sub>o</sub> load	48V <sub>DC</sub> output	--	200	300	mVp-p
		Others	--	100	200	
Trim			90	--	110	%
Output Voltage Remote Compensation(sense)			--	--	105	
Over-voltage Protection	Input voltage range	3.3V <sub>DC</sub> , 5V <sub>DC</sub> output	110	--	160	%V <sub>o</sub>
		Others	110	--	140	
Over-current Protection	Input voltage range		110	140	190	%I <sub>o</sub>
Short-circuit Protection			Hiccup, continuous, self-recovery			

Note: \*Ripple/Noise for 48V<sub>DC</sub> output at 0%I<sub>o</sub>-100%I<sub>o</sub> load ≤ 400mV, others outputs at 0%I<sub>o</sub>-100%I<sub>o</sub> load ≤ 300mV, the measuring method of ripple and noise, please refer to Fig.1.

General Specifications						
Item	Operating Conditions		Min.	Typ.	Max.	Unit
Isolation	Input-output	Electric Strength test for 1 minute with a leakage current of 5mA max.	3000	--	--	V <sub>AC</sub>
	Input-case		2100	--	--	
	Output-case	Electric Strength test for 1 minute with a leakage current of 1mA max.	1500	--	--	V <sub>DC</sub>
Insulation Resistance	Input-output resistance at 500V <sub>DC</sub>		1000	--	--	MΩ
Isolation Capacitance	Input-output capacitance at 100KHz/0.1V		--	2200	--	pF
Switching Frequency	PFM mode		--	170	--	KHz
MTBF	MIL-HDBK-217F@25°C		500	--	--	Khours

Environmental Specifications						
Item	Operating Conditions		Min.	Typ.	Max.	Unit
Operating Temperature Range	See temperature derating curves		-40	--	+105	°C
Over-temperature Protection	Out-case temperature		--	--	+115	
Storage Humidity	Non-condensing		5	--	95	%RH
Storage Temperature			-55	--	+125	°C
Pin Soldering Resistance Temperature	Soldering spot is 1.5mm away from case for 10 seconds		--	--	+300	
Cooling Test			EN60068-2-1			
Dry Heat			EN60068-2-2			
Damp Heat			EN60068-2-30			
Shock and Vibration Test			IEC/EN61373-Category 1, Grade B			

### Mechanical Specifications

Case Material	Aluminum alloy case;Black plastic bottom,flame-retardant and heat-resistant(UL94V-0)	
Dimensions	With outheatsink	60.8×39.2×12.7mm
	With heatsink	60.8×39.2×27.8mm
Weight	With outheatsink	78.0g(Typ.)
	With heatsink	109.0g(Typ.)
Cooling Method	Free air convection or forced convection	

### Electromagnetic Compatibility (EMC)

Emissions	CE	CISPR32/EN55032	150KHz-30MHz	Class B (see Fig.3 for recommended circuit)	
	RE*	CISPR32/EN55032	30MHz-1GHz	Class B (see Fig.3 for recommended circuit)	
Immunity	ESD	IEC/EN61000-4-2	GB/T17626.2	Contact ±6KV,Air ±8KV	perf.Criteria A
	RS	IEC/EN61000-4-3	GB/T17626.3	20V/m	perf.Criteria A
	CS	IEC/EN61000-4-6	GB/T17626.6	10Vr.m.s	perf.Criteria A
	EFT	IEC/EN61000-4-4	GB/T17626.4	±2KV(5KHz,100KHz)(see Fig.3 for recommended circuit)	perf.Criteria A
	Surge	IEC/EN61000-4-5	GB/T17626.5	line to line ±2KV(1.2μs/50μs 2Ω)(see Fig.3 for recommended circuit)	perf.Criteria A
	CS	IEC/EN61000-4-5	GB/T17626.5	10V r.m.s	perf.Criteria A

Note: \*The standard only suit for CFDQR50-110 series(withou theatsink).

### Electromagnetic Compatibility (EMC) (EN50155)

Emissions	CE	EN50121-3-2	150kHz-500kHz	99dBuV(see Fig.2 for recommended circuit)	
	RE	EN50121-3-2	30MHz-230MHz	40dBuV/m at 10m(see Fig.2 for recommended circuit)	
Immunity	ESD	EN50121-3-2	Contact ±6KV/Air ±8KV		perf. Criteria A
	RS	EN50121-3-2	20V/m		perf. Criteria A
	EFT	EN50121-3-2	±2kV 5/50ns 5kHz(see Fig.2 for recommended circuit)		perf. Criteria A
	Surge	EN50121-3-2	line to line±1KV(42Ω,0.5μF)(see Fig.2 for recommended circuit)		perf. Criteria A
	CS	EN50121-3-2	0.15MHz-80MHz	10V r.m.s	perf. Criteria A
	CS	EN50121-3-2	0.15MHz-80MHz	10V r.m.s	

### Typical Characteristic Curves

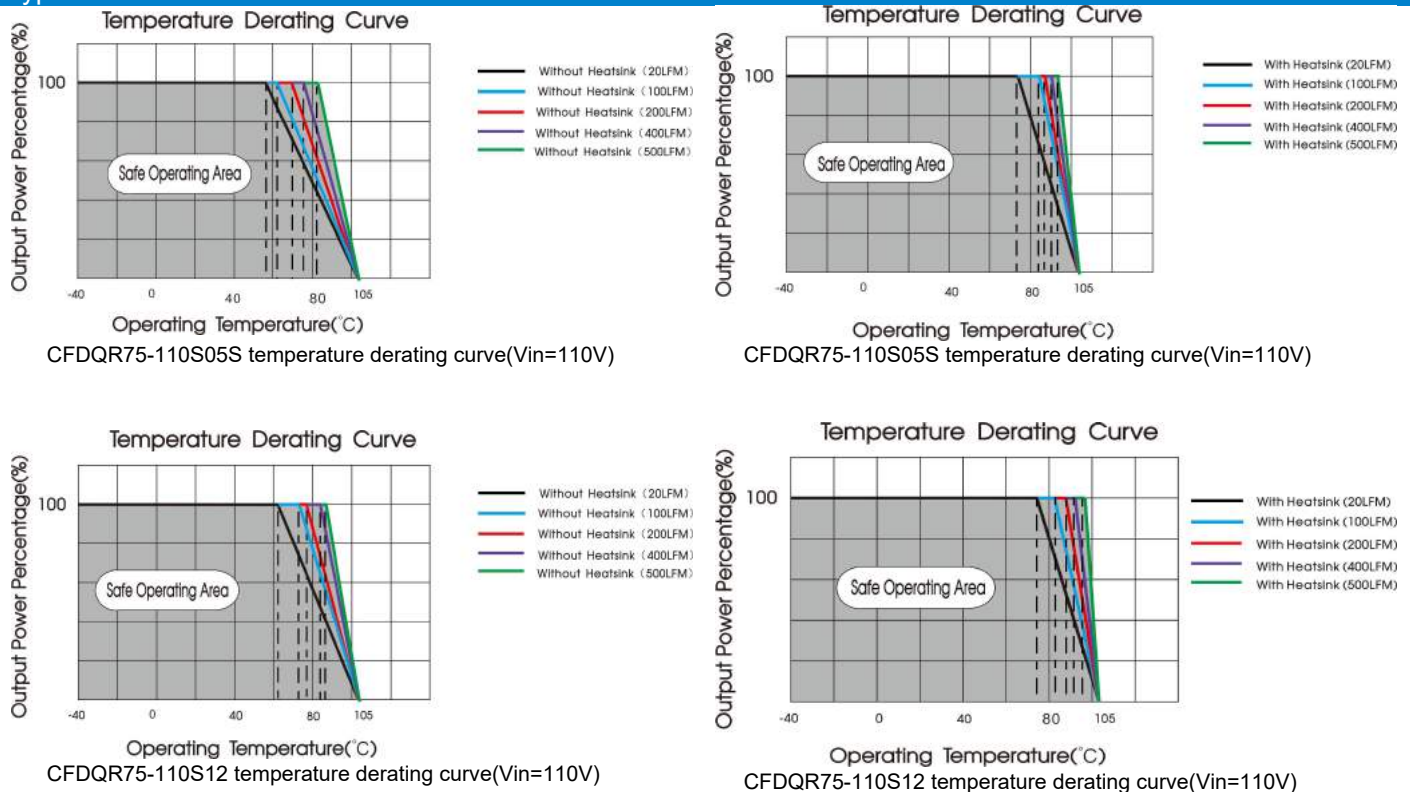

**Notes:**

- 1: Temperature derating curves and efficiency curves are typical test values.
- 2: Temperature derating curve in accordance with our laboratory test conditions for testing, the actual use of environmental conditions if the customer is not consistent, to ensure that the product a luminum shell temperature doesnot exceed 100°C, can be used within any rated load range.

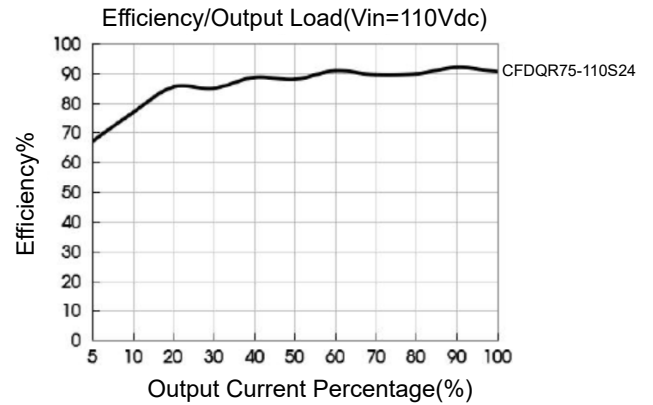
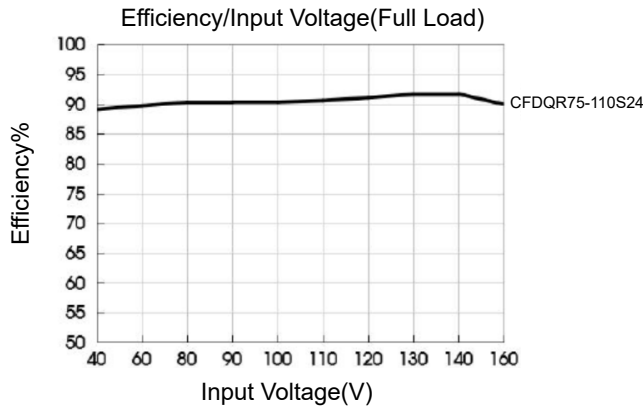
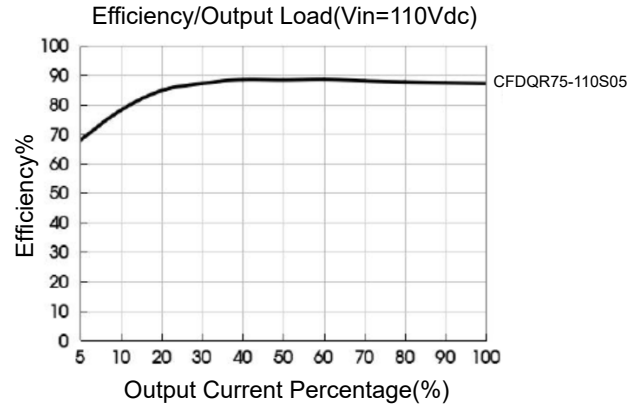
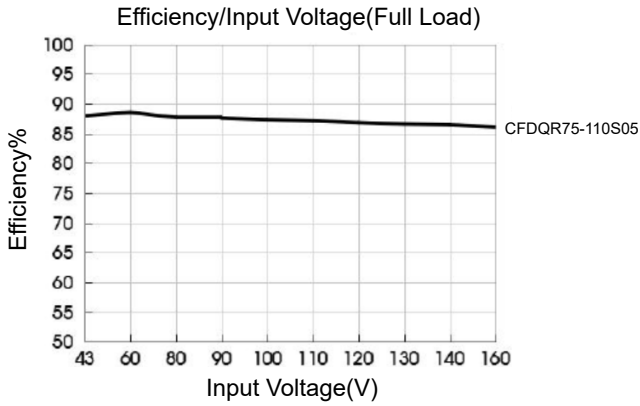

### Remote Sense Application

#### 1. Remote Sense Connection if not used

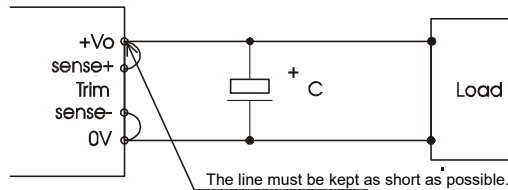

**Notes:**

- (1) If the sense function is not used for remote regulation the user must connect the +Sense to +Vo and -Sense to 0V at the DC-DC converter pins and will compensate for voltage drop across pins only.
- (2) The connections between Sense lines and their respective power lines must be kept as short as possible, otherwise they may be picking up noise, interference and/or causing unstable operation of the power module.

#### 2. Remote Sense Connection used for Compensation

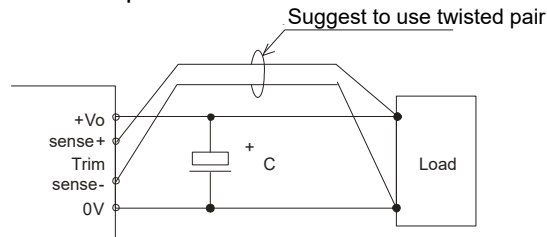

**Notes:**

- (1) Using remote sense with long wires may cause unstable output, please contact technical support if long wires must be used.
- (2) PCB-tracks or cables/wires for Remote Sense must be kept as short as possible. Twisted pair or shielded wires are suggested for remote compensation and must be kept as short as possible.
- (3) We recommend using adequate cross section for PCB-track layout and/or cables to connect the power supply module to the load in order to keep the voltage drop below 0.3V and to make sure the powersupply's output voltage remains within the specified range.
- (4) Note that large wire impedance may cause oscillation of the output voltage and/or increased ripple. Consult technical support or factory for further advice of sense operation.

## Design Reference

### 1. Ripple/Noise

All the DC-DC converters of this series are tested before edelivery using the recommended circuit shown in Fig.1.

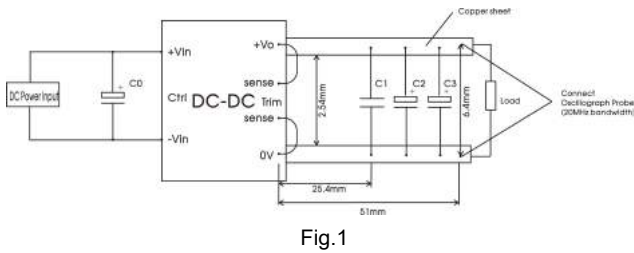

Capacitors value	C0(μF)	C1(μF)	C2(μF)	C3(μF)
Output voltage	100	1	10	1000
3.3VDC				680
5VDC				220
12VDC				
15VDC				
24VDC				
48VDC				

### 2. Typical application

We recommended using Chewins's EMC circuit, otherwise please ensure that at least a 100μF electrolytic capacitors is connected at the input in order to ensure adequate voltage surge suppression and protection.

Input and/or output ripple can be further reduced by appropriately increasing the input/output capacitor values Cin and Cout and/or by selecting capacitors with a low ESR (equivalent series resistance). Also make sure that the capacitance is not exceeding the specified max. capacitive load value of the product.



Capacitors value	Cout(μF)	Cin(μF)
Output voltage	1000	100
3.3VDC	680	
5VDC	220	
12VDC		
15VDC		
24VDC		
48VDC		

### 3. EMC compliance recommended circuit

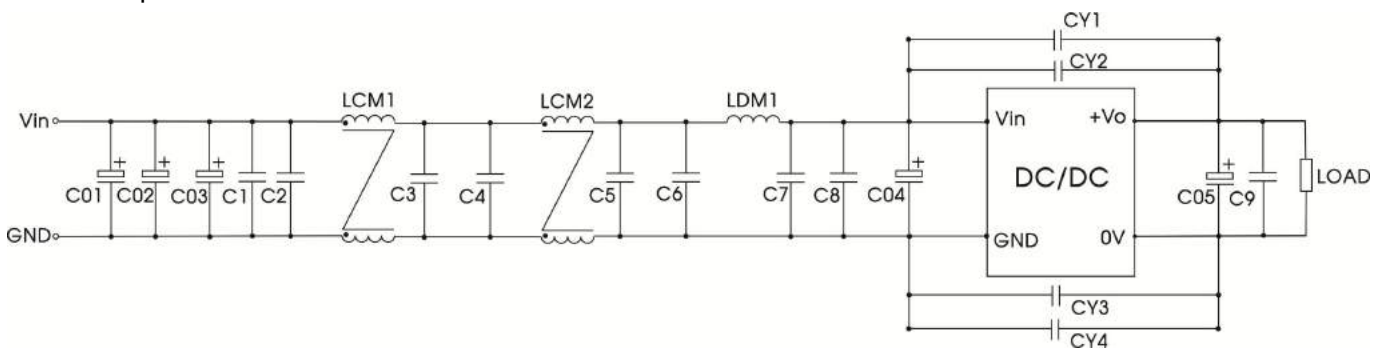

Fig.2

C01,C02,C03,C04	220uF/200V(electrolytic capacitor)
C05	220uF/63V(electrolytic capacitor)
LDM1	1.5uH(Shielded inductor)
C1,C2,C3,C4,C5,C6,C7,C8,C9	2.2uF/250V
CY1,CY2,CY3,CY4	2200pF/400V-(Ysafety capacitor)
LCM1	15mH
LCM2	2.2mH

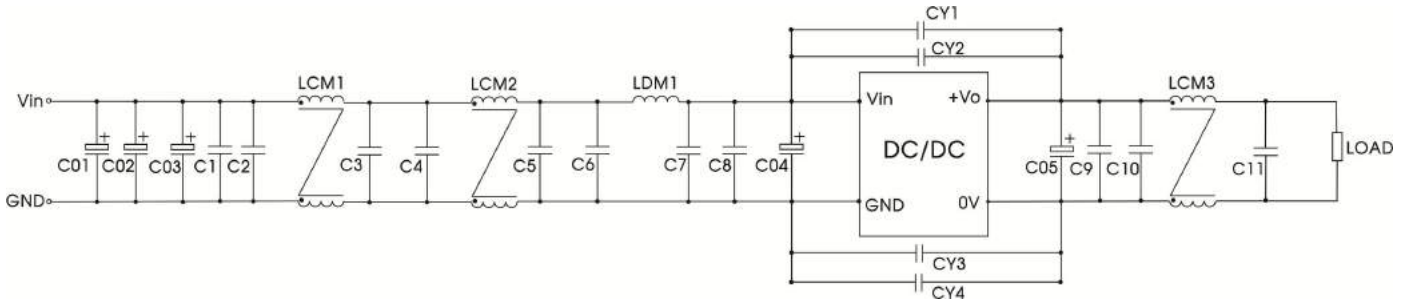
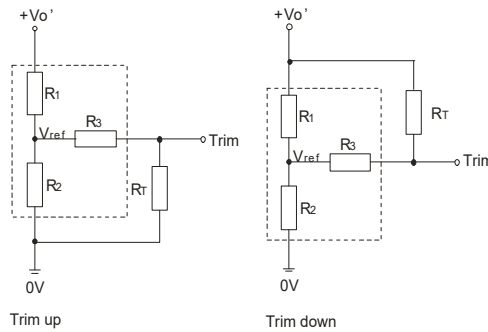

Fig.3

C01, C02, C03, C04	220uF/200V(electrolytic capacitor)
C05	220uF/63V(electrolytic capacitor)
LDM1	1.5uH(Shielded inductor)
C1,C2,C3,C4,C5, C6,C7,C8,C9,C10,C11	2.2uF/250V
CY1,CY2,CY3,CY4	2200pF/400VAC(Ysafetycapa citor)
LCM1	15mH(UU common mode inductance)
LCM2	2.2mH(UU common mode inductance)
LCM3	22uH±10%

4.Trim Function for Output Voltage Adjustment(open if unused)



TRIM resistor connection(dashed line shows internal resistor network)

Trim resistor calculation:

$$\begin{aligned} \text{up: } R_T &= \frac{aR_2}{R_2-a} - R_3 & a &= \frac{V_{ref}}{V_{o'} - V_{ref}} \cdot R_1 \\ \text{down: } R_T &= \frac{aR_1}{R_1-a} - R_3 & a &= \frac{V_{o'} - V_{ref}}{V_{ref}} \cdot R_2 \end{aligned}$$

table 1

Vo resistance	3.3(Vdc)	5(Vdc)	12(Vdc)	15(Vdc)	24(Vdc)	48(Vdc)
R1(KΩ)	4.83	8.80	11	14.49	24.87	58.7
R2(KΩ)	2.87	2.87	2.87	2.87	2.87	3.21
R3(KΩ)	9.66	11	11	16	21	11
Vref(V)	1.24	1.24	2.5	2.5	2.5	2.5

Note:

For R1,R2,R3 and Vref values refer to table 1.RT=Trim Resistor value; a=self-defined parameter Vo'=desired output voltage

5. The products do not support parallel connection of their output

6. For additional information please refer to DC-DC converter application notes on

[www.chewins.net](http://www.chewins.net)

## CFDQR75-110S05 Dimensions (without heatsink)

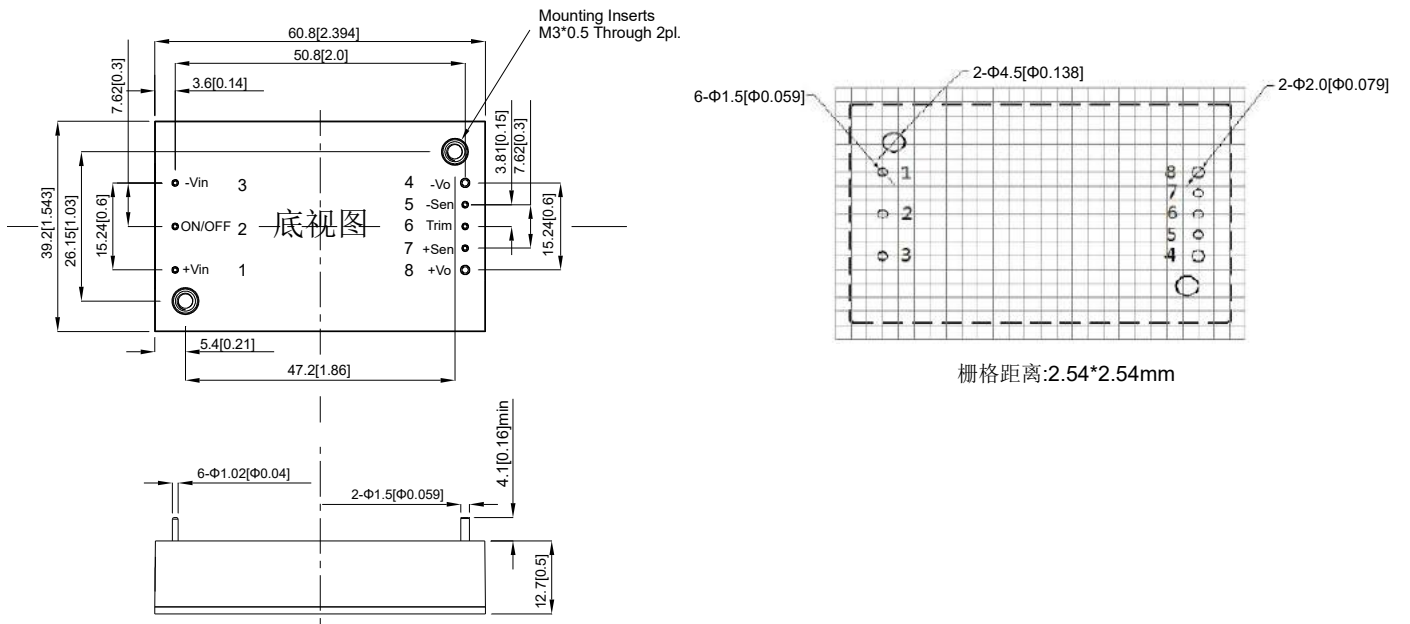

Note:  
Unit:mm[inch]  
Pin:1,2,3,5,6,7 diameter:1.0[0.039]  
Pin:4,8 diameter:1.5[0.059]  
Pin diameter tolerances:±0.5[±0.02]  
Mounting hole screwing torque:Max.0.4N.m

## CFQR75-110S05S Dimensions (with heatsink)

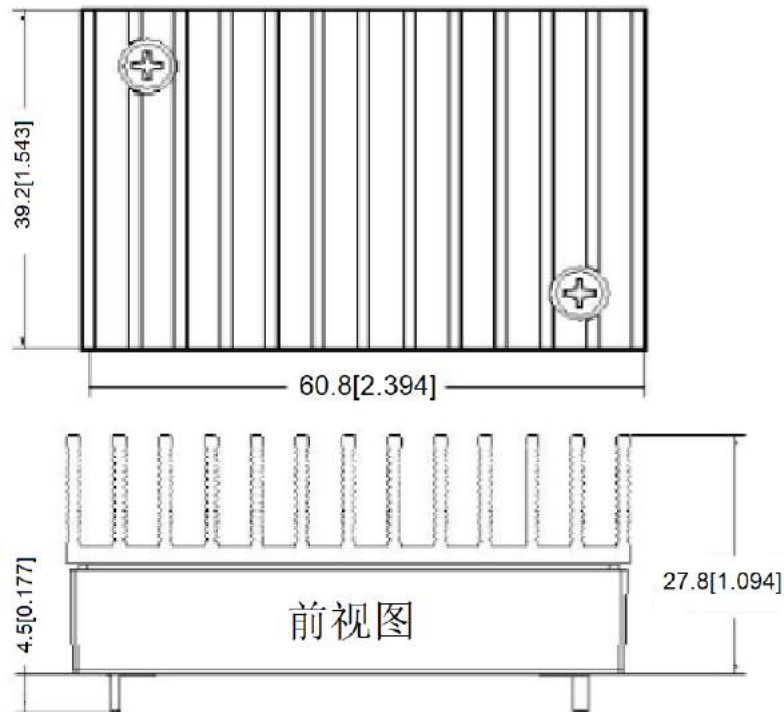

**CFQR75-110S05Z Dimensions (With base)**

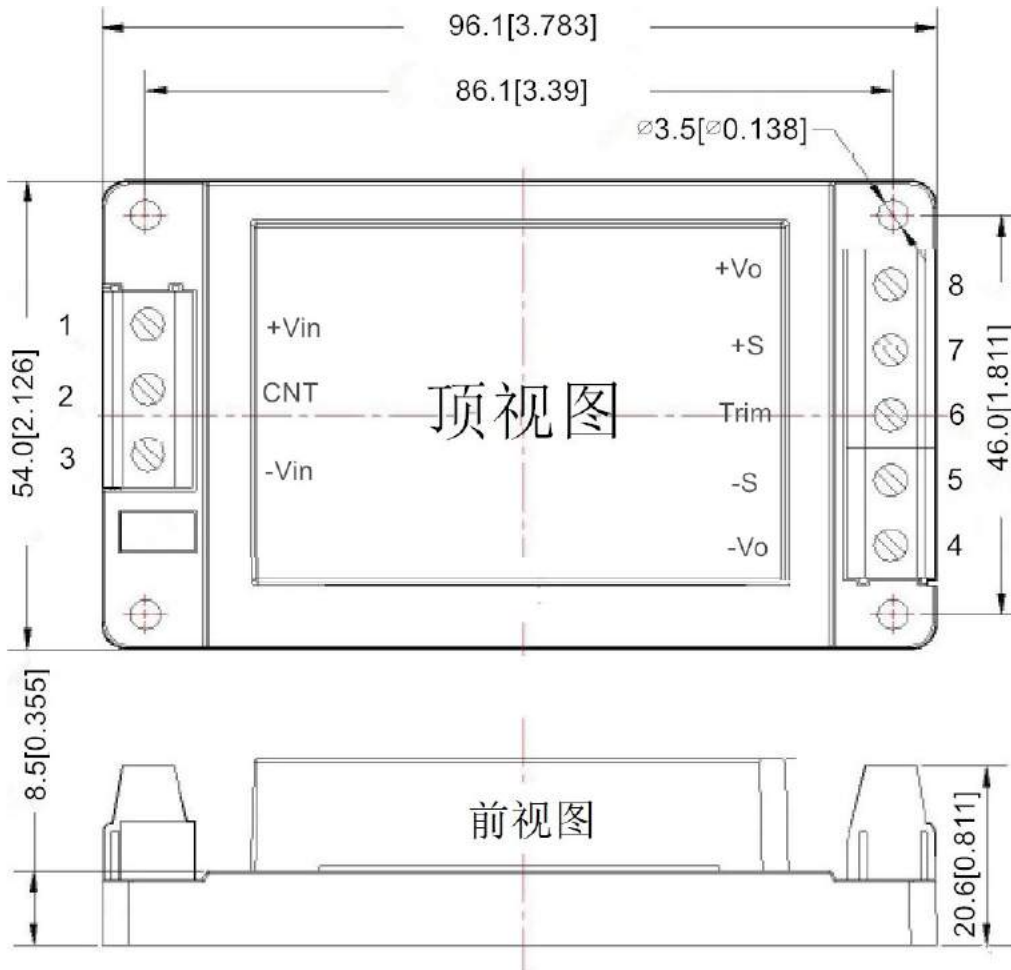

1. The recommended unbalance degree of the dual output module load is  $\leq \pm 5\%$ ; if the degree exceeds  $\pm 5\%$ , than the product performance cannot be guaranteed to comply with all parameters in the datasheet. Please contact our technicians directly for specific information;
2. The maximum capacitive load offered were tested at nominal input voltage and full load;
3. Unless otherwise specified, parameters in this datasheet were measured under the conditions of  $T_a=25^\circ\text{C}$ , humidity $<75\%$  with nominal input voltage and rated output load;  
The maximum capacitive load offered were tested at nominal input voltage and full load;
4. All index testing methods in this datasheet are based on our Company's corporate standards;
5. The performance parameters of the product models listed in this manual are as above, but some parameters of non-standard model products may exceed the requirements mentioned above. Please contact our technicians directly for specific information;
6. Specifications are subject to change without prior notice.



**CHEWINS Beijing Science & Technology Co., Ltd.**

Address: No. 25, torch South Street, Zhuozhou Development Zone, Hebei Province, people's Republic of China  
Tel:86-10-68817997 Mobile phone:15901068673 E-mail:sales@chewins.net www.chewins.net